

## Index

audio bitrate, 30  
authorising DVR3, 45  
automatic gain control, 30  
automatic recording, 44  
CAN recording, 40  
card reader, 46  
CF card  
corrupted, 18  
format, 17  
new, 17  
configuration  
exit, 22  
factory reset, 22  
read config, 22  
write config, 22  
contact details, 61  
contacting your dealer, 58  
deleting files, 18  
DVR3 module, 6  
DVR3-130 rear panel, 7  
DVR3-130 wiring, 8  
DVR3-240/440/540 rear panel, 7  
DVR3-240/440/540 wiring, 10  
firmware upgrade, 56  
frequently asked questions, 58  
front panel, 6  
harness  
DVR3-130, 53  
input, 55  
monitor, 54  
power, 55  
status, 55  
system, 54  
make a recording, 13  
manual recording, 44  
microphone bias, 30  
mounting template, 51  
pincode authorisation, 41  
play a recording, 16  
record quality, 24  
record resolution, 24  
recording lamp, 45  
recording mode, 36  
registering DVR3, 46  
screen  
advanced AGC, 31  
alarms, 37  
audio setup, 30  
camera configuration, 27  
connection, 21  
data recorder, 34  
G sensors, 38  
interfaces, 39  
record control, 36  
system information, 23  
video setup, 24  
serial port, 39  
service and support, 58  
service enquiries, 59  
specifications, 49  
triggering, 36  
troubleshooting, 48  
upgrading firmware, 56  
vehicle power, 45  
video  
bitrate, 25  
downloading, 45  
file size, 42  
index, 42  
input, 25  
intra-frame, 25  
overlay, 25  
prefix, 42  
source, 25  
synchronisation, 40, 43  
video logger, 43  
web-site, 58



---

**DVR<sup>3</sup>** Harsh Environment  
Digital Video & Data Recorders

## Users Guide

Returns Authorisation form, we will provide an estimated delivery time, subject to the outcome of the initial inspection. Priority Service – If you require your goods to be returned faster than the estimated delivery time, we offer a priority service for which there is an extra charge. Again, the time required to complete any service or repair depends on the initial inspection. Wherever possible your goods will be returned within our priority delivery times:

- **UK** – 2-3 working days
- **USA & Rest of World** – 7 working days

**Cost and Duration of Service and Repair** – On completion of the initial inspection, we will quote for the final cost and expected duration of the service and any repair work. We will ask you for authorisation to complete the work and request payment. If you choose not to proceed, we will return the goods to you as we received them and you will only be charged for the initial inspection and return freight.

**Harnesses and Sensors** – Where goods include harnesses and sensors, those will be inspected to assess functionality. We are unable to repair harnesses or sensors that have been cut or become damaged due to use.

! *A small number of sensors can be serviced or repaired. Your dealer can advise which sensors are serviceable.*

**Loan/Replacement equipment** – STACK operate a return to base service and repair policy. We do not offer an advance exchange or loan scheme.

### **STACK Contact Details**

Contact	International	United States
Email:	sales@stackltd.com	sales@stackinc.com
Web:	www.stackltd.com	www.stackinc.com

3. At the time of shipping you should arrange to make payment via your dealer for the initial inspection fee.

Your goods must be returned to STACK's factory in the UK.

The inspection and service process is explained below:

1. On receipt your goods will undergo an initial inspection by one of our engineers.
2. The engineer will attempt to reproduce the reported fault to assess the complexity of any corrective action:
  - i) If corrective action can be identified, we will contact you with details of the repair required and a quotation for that work.
  - ii) If corrective action cannot be easily identified, a full diagnosis and a "Corrective Action Assessment" will be conducted. We will then contact you to advise the next course of action and will quote on expected duration and cost of repairs where applicable.
3. Once we have received your authorisation to proceed with the repair, we will complete the work and request payment. A full final test will be conducted before the goods are packed ready for shipping.
4. Once we have confirmation that payment has been received, the goods will be returned to you.

### Cost and Duration of Service

Service and repair work is conducted at STACK's factory in the UK. The cost and duration of the service will depend on:

- Your Geographical location.
- Whether the goods are covered by a warranty.
- The complexity of the repair work required once the initial inspection has been completed.

**Cost and Duration of Inspection** – Your dealer will advise on the cost of the initial inspection. It is your responsibility to arrange for the safe shipment of the goods.

The time required to complete any service or repair work depends on the initial inspection. Upon receiving your

## Preface

### Congratulations

Thank you for choosing STACK's DVR3. This solid-state recorder will give you many opportunities to make video recordings in environments where ordinary digital video recorders cannot be used.

### Purpose of this User Guide

This user guide will help you install and use your STACK DVR3. It explains how to set up and configure the system for your application.

### Related Products From Stack

If you need information about other STACK products, these can be obtained from your local STACK dealer. Products available include :-

- Digital Video Loggers (DVL) & Digital Video Recorders
- Multi-function Recorders (MFR)
- Multi-function Displays (MFD)
- Tyre Pressure Monitoring Systems (TPMS)
- Health & Usage Monitoring Systems (HUMS)
- Event Recorders
- Data Analysis Software
- Pro-control & Professional Auxiliary Gauges
- Intelligent Tachometers & Integrated Displays
- Analogue & Digital Sensors

STACK ® is a registered trademark of STACK Limited.

Information in this publication is subject to change without notice and does not represent a commitment on the part of STACK Limited. No responsibility is accepted for error or omission.

Copyright © 2013 STACK Limited

# Contents

<b>Chapter 1. Introduction.....</b>	<b>1</b>
<b>Chapter 2. Essential User Information .....</b>	<b>3</b>
Video Standard .....	4
Using a New Compact Flash Card .....	4
Playing a Recording .....	4
Before Making a Recording .....	4
Deleting Files .....	5
<b>Chapter 3. Installation .....</b>	<b>6</b>
DVR3-130 Wiring .....	8
DVR3-240/440/540 Wiring .....	10
<b>Chapter 4. Operation .....</b>	<b>13</b>
To make a recording: .....	13
To play a recording: .....	16
Operation with a new Compact Flash Card .....	17
Formatting a Compact Flash Card .....	17
Deleting Files .....	18
Corrupted Compact Flash Cards .....	18
<b>Chapter 5. Compact Flash Cards .....</b>	<b>20</b>
<b>Chapter 6. Configuration .....</b>	<b>21</b>
Connection .....	21
Information .....	23
Video Setup .....	24
Camera Configuration .....	27
Audio Setup .....	30
Advanced AGC .....	31
Data Recorder .....	34
Record Control .....	36
Alarms .....	37
G Sensors .....	38
Interfaces .....	39
Pincodes .....	41
Misc .....	42
<b>Chapter 7. Video and Data Systems .....</b>	<b>43</b>

- **Date of purchase**
- **The packing list supplied with the product**
- **If it is a Data Logging product, please provide the TAG or Serial number, software licence number and DataPro version. Your Dealer will help you locate those numbers.**

## Service Enquiries

If you or your Dealer have identified a fault with your STACK equipment, it is possible to return the goods for inspection. Your dealer will help you with this. Before returning your equipment, please be aware that:

- All services and repairs are subject to an initial inspection. No commitment can be made to repair the goods in full or within a specified budget or timescale until this inspection is complete.
- An initial inspection fee will be charged for all services and payment is required before we conduct the inspection. On completion of the inspection, you will be advised of any work and the costs involved in repairing the goods. At this point you have the choice to proceed or terminate this service.
- It is your responsibility to safely ship (at your expense) the goods to STACK. It is also your responsibility to arrange for the safe return of the goods unless they are repaired under warranty, in which case STACK will organise their return. Please ensure that goods are adequately packaged and insured for the journey.

To arrange for your equipment to be returned for inspection, please contact your dealer. The process for returning goods is as follows:

1. Your dealer will complete and send you a Returns Authorisation form by email, fax or post. This form includes a unique Returns Authorisation Number (RAN).
2. You must include that form with the goods when shipped. Your dealer will advise you about shipping.

## Appendix D. Service and Support

STACK takes pride in having a very high-quality engineered product range and strive to offer first class service when supporting our customers.

### STACK Web-site

If you have questions about STACK products or are experiencing a problem, a wealth of information is available on our web-sites to find the answers you need.

International	United States
<a href="http://www.stackltd.com">www.stackltd.com</a>	<a href="http://www.stackinc.com">www.stackinc.com</a>

### Frequently Asked Questions

Log-on to the STACK web-site, click on Video Systems and then Customer Support. Then either select Service & Support and click on the FAQ link or select Troubleshooting.

If you need a User Guide, click on Manuals and Instructions. You must enter some basic information for STACK's internal use to gain access to downloadable versions of our product manuals. These give clear instructions on installation and correct operation of your STACK product.

**!** *If you still have questions, please contact your Dealer.*

### Contacting your Dealer

For a current list of dealers, log-on to the STACK web-site, click on Video Systems and then Customer Support. Finally select Where to buy.

When making contact it is important you have the following information to hand to help your Dealer ensure your enquiry is handled in an efficient manner:

- Serial Number (found on the rear of the product)
- Model Number

Controlling Synchronised Video .....	43
Manual recording control.....	44
Recording Lamp.....	45
Recommended Vehicle System Power connections.....	45
Downloading Video .....	45
<b>Chapter 8. Troubleshooting.....</b>	<b>48</b>
<b>Chapter 9. Specifications .....</b>	<b>49</b>
<b>Appendix A. Mounting Template.....</b>	<b>51</b>
<b>Appendix B. Wiring Harness Diagrams .....</b>	<b>53</b>
DVR3-130 Harness (ST918119) 53	
DVR3-240/440/540 System Harness (ST918118) 54	
DVR3-240/440/540 Monitor Harness (ST918114) 54	
DVR3-240/440/540 Input Harness (ST918107) 55	
Power Harness (ST918078) 55	
Control & Status Harness (ST918105) 55	
<b>Appendix C. Upgrading the Firmware .....</b>	<b>56</b>
<b>Appendix D. Service and Support .....</b>	<b>58</b>
STACK Web-site 58	
Contacting your Dealer 58	
STACK Contact Details 61	
<b>Index.....</b>	<b>62</b>

9. Locate the upgrade file you previously downloaded.

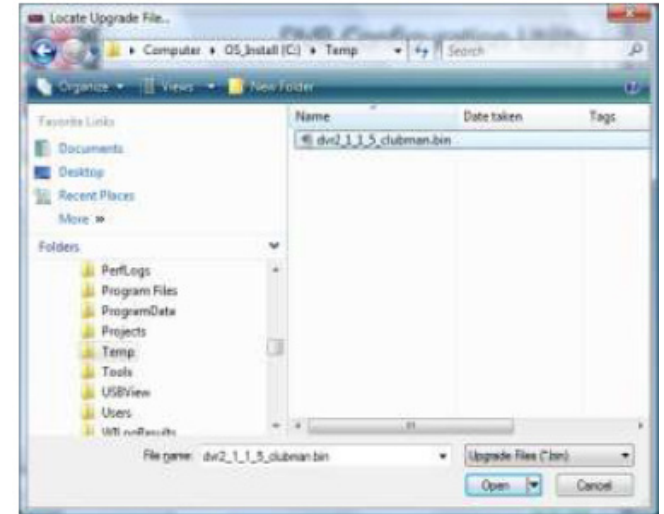

10. When prompted, unplug the USB lead connecting DVR3 to your computer and click **OK**.



11. The upgrade process takes about one minute and, during that time, the DVR3 Status LED will be red.

! *Do not remove power from DVR3 until the upgrade process is complete and the Status LED shows green. Removing power during the upgrade process may need the unit to be returned to STACK for reprogramming.*

12. Reconnect DVR3 to your computer via the USB lead.  
 13. Confirm on the **Information** tab within the DVR Configuration Utility that the DVR3 software version number has changed.  
 14. If you previously saved your configuration, reload it by clicking the **Import** button. Once loaded, click Write Config. to upload it to the upgraded DVR3.

## Appendix C. Upgrading the Firmware

From time to time STACK may release upgrades to the firmware within your DVR3. These can be found on the STACK web-site which we suggest you visit occasionally to find out if an upgrade is available.

### STACK DVR3 Firmware Upgrade Instructions

1. Open your Web Browser and navigate to the STACK DVR3 Firmware Upgrade webpage :- <http://www.stackltd.com/dvrfirmware>
2. Locate the latest firmware upgrade binary file for your model and click the link to download it.
3. When prompted, click the Save button and choose a location for the file on your computer.
4. Once the file has been downloaded, start the STACK DVR Configuration Utility on your computer.
5. Insert a Compact Flash card with at least 20MB of free space into DVR3 and switch the power on.
6. Connect DVR3 to your computer using the USB lead provided and wait for communications to be established.
7. Select the **Information** tab within the Configuration Utility and, if there is already a configuration loaded, save it by clicking the **Export** button.
8. Now click the **Upgrade** button and click **Yes** to the prompt about losing the configuration.

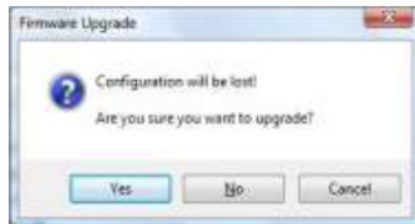

## Chapter 1. Introduction

DVR3 is part of STACK's third generation Digital Video Recorder range. Specially designed for harsh environments, they provide the optimum solution for capturing audio and video on the move. Now they record data too...

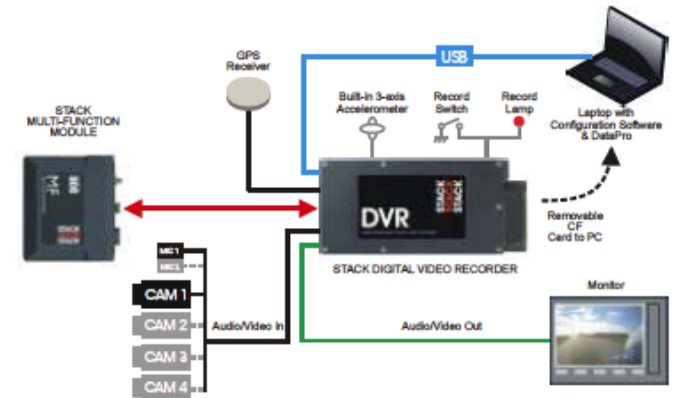

Typical DVR3 Application

STACK's Digital Video Recorders employ broadcast standard MPEG-2 video compression to record high quality real-time video and audio direct to a Compact Flash (CF) card. The card is easily removed and played on a PC or laptop using a standard media player application. Recordings can also be copied to DVD for playback on either a PC or DD player.

A data overlay feature is available so that date, time and GPS data may be stamped onto the recorded video. Connecting the DVR3 directly by CAN-bus to a STACK Data System allows up to 256 channels of data, including GPS and the internal 3-axis G sensor channels, to be recorded alongside the video and audio. The recording can be viewed and analysed in the supplied STACK DataPro analysis software. STACK DVR3s feature a rugged machined aluminium housing specifically designed and manufactured to protect

STACK's Digital Video Recorders employ broadcast standard MPEG-2 video compression to record high quality real-time video and audio direct to a Compact Flash (CF) card. The card is easily removed and played on a PC or laptop using a standard media player application. Recordings can also be copied to DVD for playback on either a PC or DD player.

A data overlay feature is available so that date, time and GPS data may be stamped onto the recorded video. Connecting the DVR3 directly by CAN-bus to a STACK Data System allows up to 256 channels of data, including GPS and the internal 3-axis G sensor channels, to be recorded alongside the video and audio. The recording can be viewed and analysed in the supplied STACK DataPro analysis software. STACK DVR3s feature a rugged machined aluminium housing specifically designed and manufactured to protect

## DVR3-240/440/540 Input Harness (ST918107)

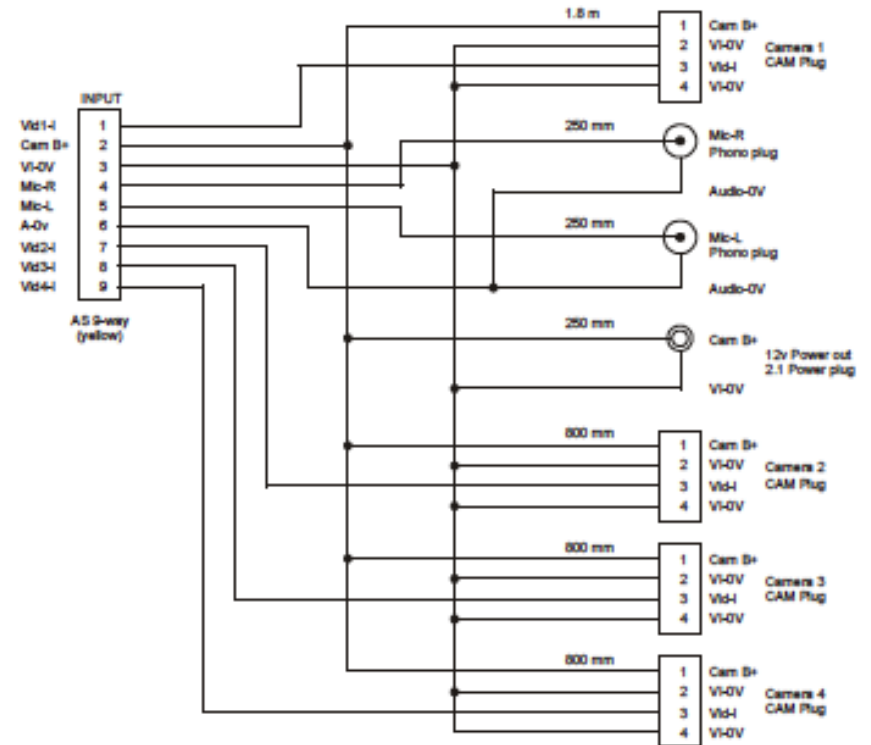

## Power Harness (ST918078)

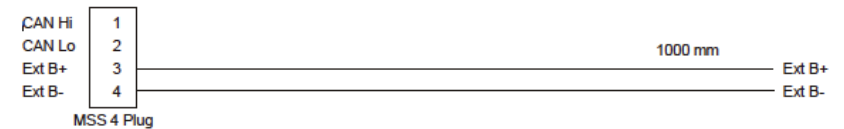

## Control & Status Harness (ST918105)

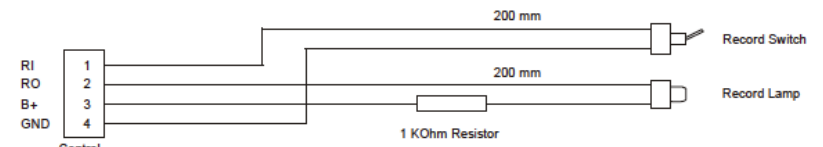



## DVR3-240/440/540 System Harness (ST918118)

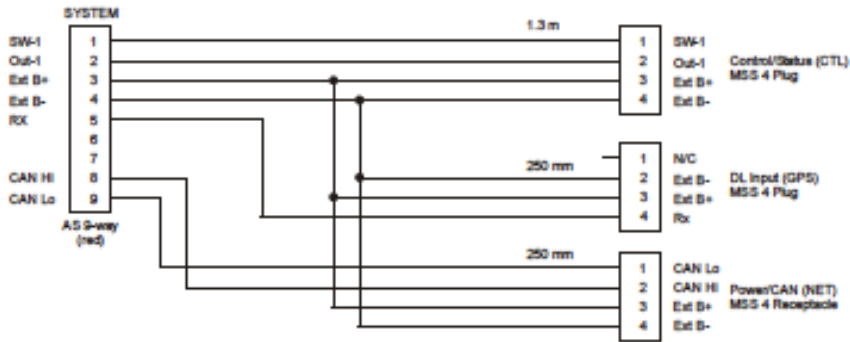

## DVR3-240/440/540 Monitor Harness (ST918114)

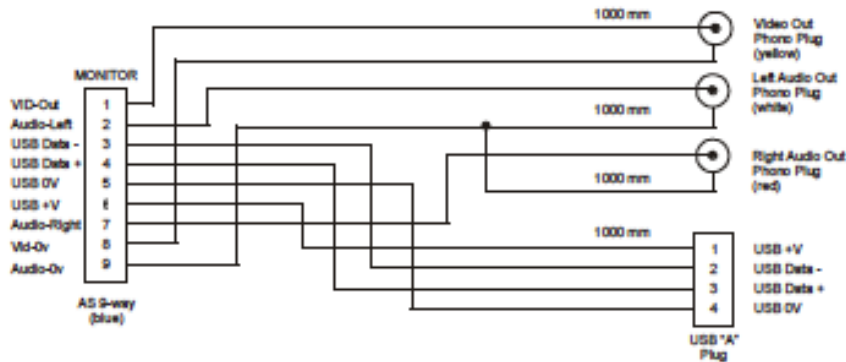

## Chapter 2. Essential User Information

Please read this chapter before using your STACK DVR3.

### DVR3-130 Standard Components

Quantity	Description
1	ST9374 DVR3-130 Module
1	ST918119 DVR3-130 System Harness
1	ST918105 Control and Status Harness
1	ST169049 USB DVR3 to PC Lead
1	ST918078 Power Harness
1	ST169021 Audio/Video Lead
1	ST920039 DVR Configuration Utility Software

### DVR3-240/440/540 Standard Components

Quantity	Description
1	of ST9373 DVR3-240 Module ST9377 DVR3-440 Module ST9379 DVR3-540 Module
1	ST918118 System Harness (red)
1	ST918107 Input Harness (yellow)
1	ST918114 Monitor Harness (blue)
1	ST918078 Power Harness
1	ST918105 Control and Status Harness
1	ST920039 DVR Configuration Utility Software
4	ST918106 BNC Adapter (standard on DVR3-440 & 540)

### Optional Components

Quantity	Description
1	or ST918129 Expansion harness for ST8100, ST8130 etc ST918130 Expansion harness for MF, MFR, MFD etc
up to 4	Bullet Camera (ST8393 PAL or ST8394 NTSC)
up to 4	ST918106 CAM plug to BNC & Power Harness
up to 4	ST169047 2 metre Camera Extension Cable
up to 4	ST39008x Camera Mount
1	ST8392 Microphone Kit ST3900xx Compact Flash (CF) Card
1	ST995 GPS Receiver

## Video Standard

DVR3 can be configured to either the PAL or NTSC video standard to match the camera which is connected.

! Only PAL and NTSC are currently supported.

## Using a New Compact Flash Card

DVR3 will only operate with a Compact Flash card formatted with a FAT32 File System. Before using a new card, check its File System by inserting it into a PC running Windows XP or Vista and display the disk properties by right clicking the disk icon in “My Computer”. If supplied as FAT16, reformat to FAT32 (see page 17).

## Playing a Recording

The files produced by DVR3 are fully MPEG-2 compliant. They may be played directly from the card by inserting it into a PC with a suitable Compact Flash card slot or adapter. However, better replay results are usually obtained by transferring the file to the PC’s hard drive (see page 16).

## Before Making a Recording

Before a recording session clear the Compact Flash card so that maximum space is available. Deleting files can cause the write/read speed of the removable Compact Flash card to degrade but a format will restore its performance. A format can be achieved using a PC running Windows XP or Vista. Right-click on the disk icon in “My Computer” and select “Format”. Ensure the “File system” is set to “FAT32”, choose the “Quick Format” option and then click “Start” (see page 17).

Alternatively click on the “Information” tab in the DVR Configuration Utility and select “Format”. (see page 23)

## Appendix B. Wiring Harness Diagrams

DVR3-130 Harness (ST918119)

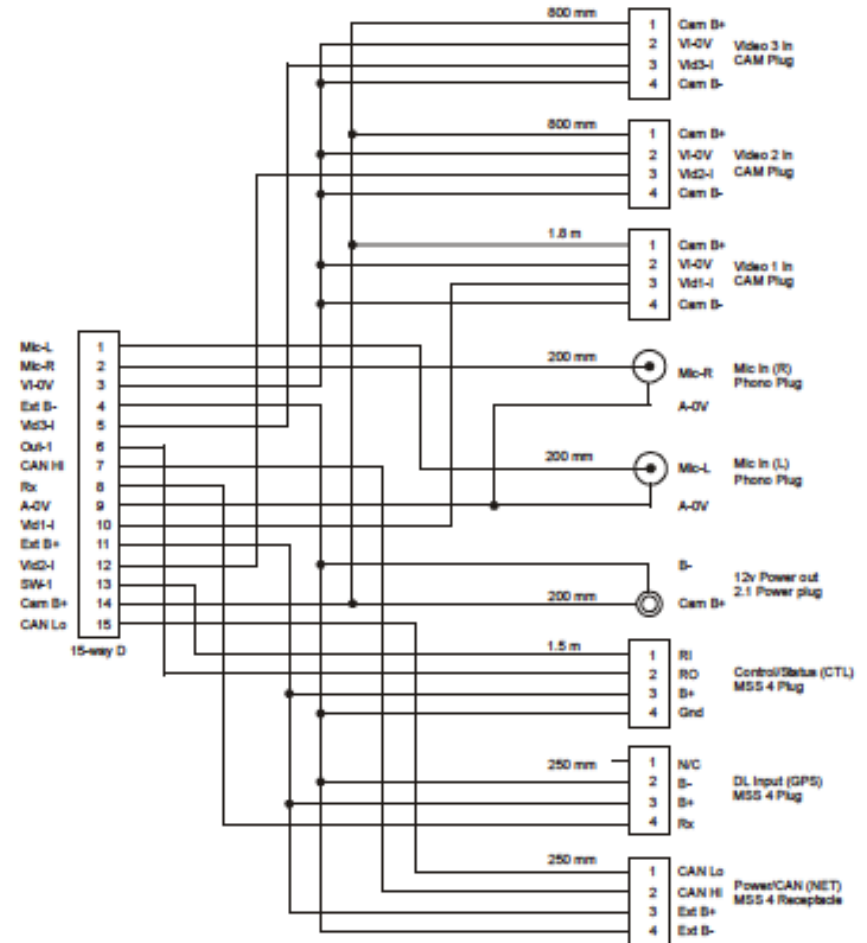

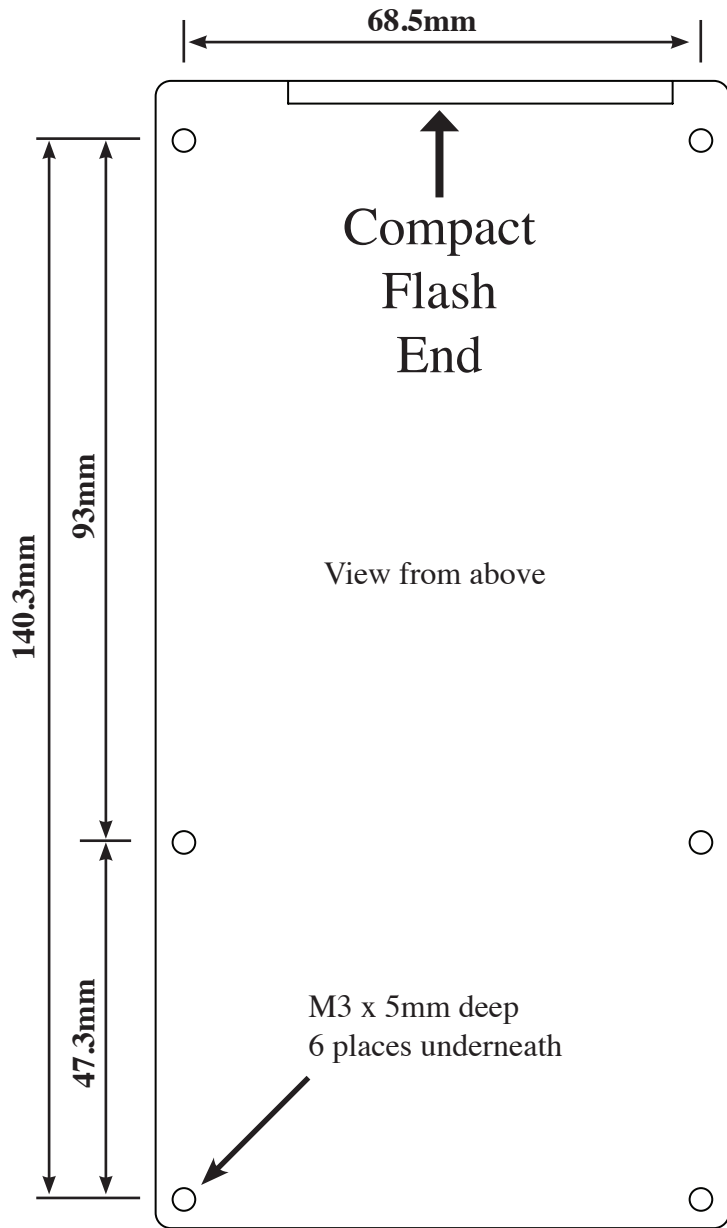

## Deleting Files

Whilst it is possible to delete files from the CF card, that won't necessarily restore full performance due to file fragmentation. To restore performance once a recording has been made, transfer the files to your PC's hard drive and then perform a format.

- ! *Ensure any useful recordings have been archived before performing a format.*

## Chapter 3. Installation

Before installing DVR3, take a few moments to plan the installation. First identify all the components which came with your system. You may like to perform a dry run by connecting the components together to get a feel for how the final installation will be accomplished.

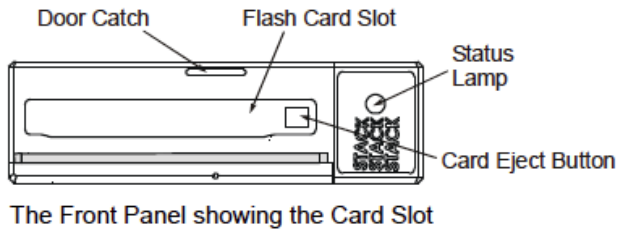
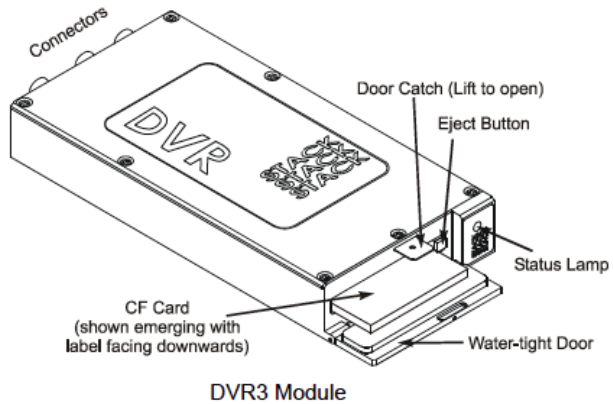

## Appendix A. Mounting Template

Use the template on the next page for mounting DVR3.  
Remember to leave room for card insertion and removal..

Switch to recording delay	< 0.5 seconds
Video lost between files	< 0.5 seconds
Video lost at power failure	< 1 second
<b>Video</b>	
Number video channels	DVR3-130 = 3 DVR3-240/440/540 = 4
Video standards	PAL, NTSC (RS170,RS170A)
Frame Rate	25 fps (PAL), 30 fps (NTSC)
Composite Video Input	1.0 V pk-pk
Composite Video Output	1.0 V pk-pk
Compression format	MPEG-2 (MP@ML PS)
Resolutions supported	See Table on page 24
CF Recording time (at D1 resolution)	7 to 140 minutes per Gbyte
Quality bit-rates:	1, 2, 4, 5, 6, 8, 10, 12, 15, 20 Mbps

**Audio**

Channels	2 In, 2 Out (0 to -40dB)
Analogue Input	Line level
Automatic gain control	AGC
Microphone bias	2.5v 10k Option
Compression format	MPEG-1 (Layer 2)

**Real Time Clock**

Accuracy	±2 seconds per day
----------	--------------------

**Environmental****Operating temperature range\* :**

DVR3-130	0 to 50°C (32 to 122°F)
DVR3-240	0 to 70°C (32 to 158°F)
DVR3-440/540	-20 to 80°C (-4 to 176°F)

**Sealing :**

DVR3-130	CF door only
DVR3-240/440/540	IP67

*Specification is for DVR3 only. When combined with a CF card, the specifications will be reduced to the lesser of the two.*

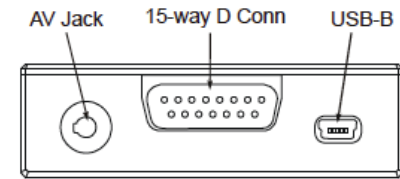

DVR3-130 Rear Panel showing the Connectors

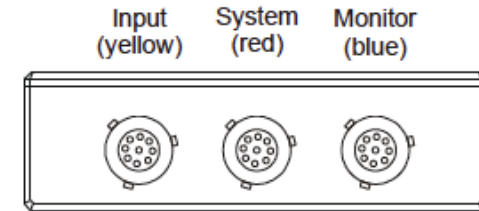

DVR3-240/440/540 Rear Panel

Now identify a suitable location for DVR3. It can be mounted in any orientation but, when looking for a location, please bear in mind that there must be approximately 50mm (2") clearance for the wiring harnesses at the back of the unit to ensure that the cables will not be bent too sharply. There must also be enough space to remove the Compact Flash card at the front.

The module can be mounted by various means including using double-sided tape or Dual-Lock™. A rigid mounting can be made to a suitable bracket using the six M3 tapped holes in its underside (see Appendix A. Mounting Template for dimensions).

Once a mounting position has been determined, the components should be connected using the wiring harnesses supplied. The figures below show the standard electrical connections to the unit.

If you are using DVR3 with a STACK Video Overlay system, an adapter harness is available for that system. The differences are described at the end of this chapter. Please

contact your STACK dealer if you need to purchase the adapter wiring harness.

! *The wiring harnesses supplied by STACK are terminated with commonly used connectors. If your equipment uses different connectors, please obtain appropriate adapters, available from your STACK dealer.*

## DVR3-130 Wiring

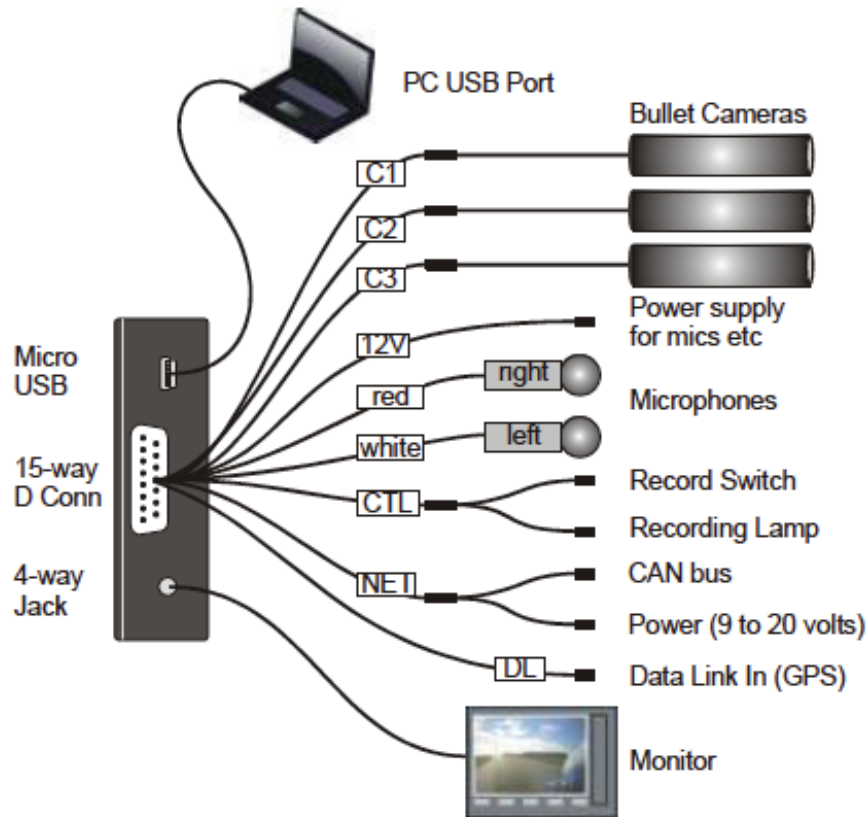

Starting from C1, connect a camera to each of the 4-way CAM plugs on the wiring harness.

! *If you are using your own cameras, you may need to obtain the optional CAM plug to BNC and Power leads (ST918106) from your STACK dealer.*

## Chapter 9. Specifications

### General

Video Standard	PAL and NTSC
Power Input	9 V to 20 V DC 20-50V Option (ST9399)
Power Over-voltage	-60 V to +60 V
Power Consumption	~5 W (without cameras etc)
Maximum load	3.5A for 10 mS (in-rush current at power on)
Standby battery life	> 5 years
Case Dimensions	151 x 76 x 21 mm
Case Material	Hard anodised aluminium.
Weight	300g (without CF card)
Electrical Connectors :	
DVR3-130	15w D, 4w jack, Micro USB
DVR3-240/440/540	3 x 9w AS

### Configuration

Operating System	Windows XP, Vista or Win 7
Connection	Configuration uploaded from PC via USB cable

### Recording Media

Removable card	Compact Flash
Maximum Media size	128 Gbyte
Maximum File size	2 Gbyte - Larger recordings automatically fragmented into 2 Gbyte files with < 0.5 second gaps

File Format	MPEG-2 DVD compatible
Media supply voltage	3.3v DC
Media format	PC FAT32

### Recording Control

Record switch	TTL Compatible with 22K pull up to 5.0 volts.
Status Lamp (internal)	Bi-colour green/red
Recording Lamp output	Open collector (50 volt max)
Power on to recording delay	< 20 seconds



## Chapter 8. Troubleshooting

Symptom	Possible	Remedy	Notes
DVR3 will not operate with a new Compact Flash card.	The new Compact Flash card has an incorrect file system.	Set the Compact Flash card to the FAT32 file system	To check the CF card's file system, insert the card into a PC and display its properties (see page 17)
Video files are corrupted or missing	DVR3 was switched off before recording finished	Ensure recording has finished before switching off DVR3.	Use Windows Check Disk utility to recover damaged recording files (see page 18)
My media player will not play DVR3 files.	DVR3 files have a MPEG-2 format and some media players can only play MPEG-1 by default.	Install an MPEG-2 decoder on your PC or use another MPEG-2 player.	If the PC does not have a DVD drive / player installed, you may need to obtain a plug-in for your media player. This can be obtained via the Microsoft Update website.
Video will not play back correctly on a DVD player.	Record Resolution is too low.	Increase Record Resolution to its highest setting.	Many domestic DVD players will not work with low resolution video files.
Video Playback is "jerky" or "hesitates".	The transfer rate from the Compact Flash card to the PC is not fast enough.	Copy the video file to the computer's hard drive and play the copied file from that location.	Where the transfer rate is nearly high enough, it is sufficient to pause playback for a few seconds to fill your media player's buffer. Often the file will play correctly from then on saving the timeconsuming transfer to the PC's hard drive.
Video Playback is "jerky" and the picture is incomplete or has extra lines.	Incorrect video standard selected.	Check DVR3 is configured for video of the same standard as the video source (NTSC or PAL).	Check this using the DVR Configuration Utility which shows how DVR3 is configured and the standard of the video source.
GPS not displaying or recording	Incorrect Baud rate selected for serial port	Check DVR3 is configured for the correct Baud rate	STACK's ST995 GPS module must use 9600 Baud

Connect the Record Switch and Recording Lamp lead to the CTL connector. Extender cables are available from Stack's dealers.

The Recording Lamp output can be used to drive an input on some other equipment to indicate DVR3 is recording. This is an open collector output and must not be used to drive more than 25mA max.

Connect a permanent DC supply of between 9 and 20 volts (or 20 to 50volts for the High Voltage Option ST9399) to the Power (B+ and B-) connectors. You must provide a 5 amp fuse in the B+ connection to protect DVR3. An independent switch can be added to isolate the module.

- ! *A permanent power supply is required to ensure that recording finishes cleanly when the Record Switch is turned off. If the supply is obtained from a vehicle's ignition switch, DVR3 could switch off before the recording has finished and the last few seconds may be lost (see page 18).*

The following connections are optional:

If audio recording is required, connect your microphones to the white (left) and red (right) microphone inputs. Microphone gain can be adjusted using the DVR Configuration Utility (see page 30). A Regulated 12 volt 2.1 mm power connector has been provided for powering microphones.

- ! *The regulated 12 volt power also supplies the camera. The maximum total load is 1.0 Amps so, if the current required is greater, you must provide a separate power supply.*
- ! *If audio recording is not required, it may be disabled to extend the recording time (see page 30).*

same as the input. Connect the yellow phono plug to the video input on your monitor.

Stereo audio monitor outputs are also provided to aid the setup of the microphone levels (see page 30). Connect the white and red phono plugs to the audio inputs on your monitor or speakers.

### DVR3-240/440/540 Wiring

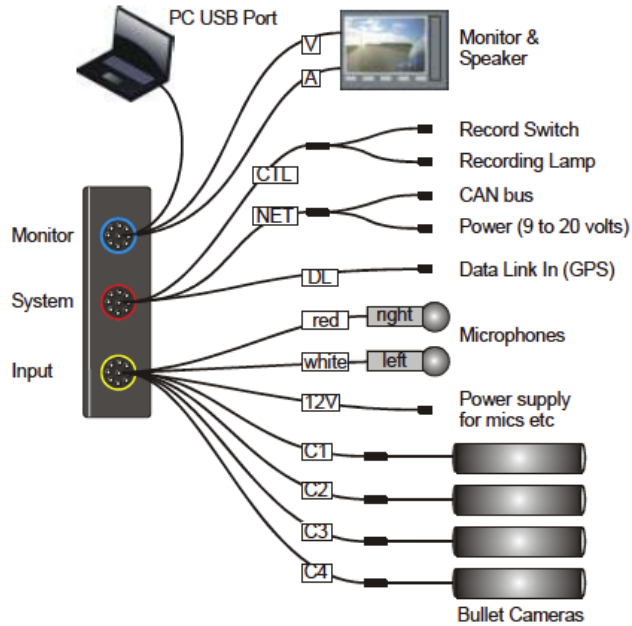

Plug each harness into the appropriately coloured connector on the rear panel of DVR3.

If no Card Reader is available, it is possible to put DVR3 into Card Reader mode. Leave the CF card in place and connect the USB cable. Start up the DVR Configuration Utility and click the Card Reader button on the Information tab. This will open the CF Card as a drive, eg F: in Windows Explorer.

If you haven't recorded any data, all you need do is copy the video files to your hard disk for viewing with a media player. However, if you have recorded synchronised data, you need to download that to STACK's DataPro analysis software.

Start DataPro, select DVL Download from the Recorder menu and the following dialog box will be displayed.

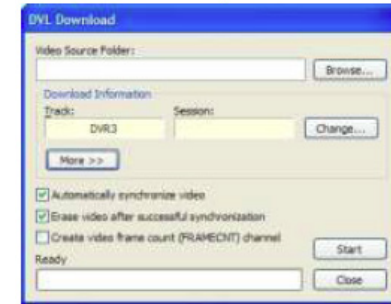

! *If DataPro is running, this dialog box should pop up automatically when a CF Card is inserted into the Reader.*

Use the Browse button to select your Card Reader, then click Start. The video file will be copied to your PC and any data it contains will be extracted so you may view it in DataPro. You may choose a different Track and/or Session by clicking the Change button.

Normally video files will be deleted from the CF card but, if you would prefer not to do that, uncheck the "Erase video..." box.

! *It is good practice to delete video files after copying them so that your CF card is ready to make new recordings.*



Click **New** then enter the **Serial Number** of your DVR3 into the **Tag Number** field as a seven digit number including leading zeros, eg, “0023902”.

Then enter your sixteen-digit **PIN Code**.

Finally click **Authorise** to complete the authorisation process.



! Do not click the **Get Tag** button.

## Registering DVR3

Before downloading data from DVR3 it must be registered with DataPro. Select **Download Manager** from the **Run Data** menu. Click **Add Vehicle** to pop up the following dialog box.

Use this screen to enter a **Name** for your DVR3 and choose a **Session** for it to download into.

Enter the **Serial Number** of your DVR3 into the **Tag** field as a seven digit number including leading zeros, eg, “0023902”. The Serial Number can be found on the **Information** tab of the DVR Configuration Utility. Finally click OK to dismiss the box.



## Card Reader

DVR3 records video and data onto a removable CF Card. The best method for downloading data to your PC is to take the card out of its slot in DVR3 and insert it into a Card Reader connected to your PC.

## Input Harness (yellow)

Starting from C1, connect a camera to each of the 4-way CAM plugs on the wiring harness.

! If you are using your own cameras, you may need to obtain the optional CAM plug to BNC and Power leads (ST918106) from your STACK dealer.

The following connections are optional:

If audio recording is required, connect your microphones to the white (left) and red (right) microphone inputs.

Microphone gain can be adjusted using the DVR Configuration Utility (see page 30).

A Regulated 12 volt 2.1 mm power connector has been provided for powering microphones.

! The regulated 12 volt power also supplies the cameras and optional GPS Receiver. If the maximum total load is greater than 1.0 Amp, you must provide a separate power supply.

! If audio recording is not required, it may be disabled to extend the recording time (see page 23).

## System Harness (red)

Connect the Record Switch and Recording Lamp lead to the CTL connector. Extender cables are available from Stack’s dealers.

The Recording Lamp output can be used to drive an input on some other equipment to indicate DVR3 is recording. This is an open collector output and must not be used to drive more than 25mA max.

Connect a permanent DC supply of between 9 and 20 volts (or 20 to 50volts for the High Voltage Option ST9399) to the Power (B+ and B-) connectors. You must provide a 5 Amp fuse in the B+ connection to protect DVR3. An independent switch can be added to isolate the module.

! A permanent power supply is required to ensure that recording finishes cleanly when the Record Switch is turned off. If the supply is obtained from a vehicle’s ignition switch,

*DVR3 could switch off before the recording has finished and that recording may be lost (see page 18).*

Connect a GPS receiver into the DL (Data Link) connector input for GPS video overlay (see page 39)

#### **Monitor Harness (blue)**

The composite video output can be used to connect to an external monitor to help align the camera, etc. The video monitor output is the same as the input. Connect the yellow phono plug to the video input on your monitor.

Stereo audio monitor outputs are also provided to aid the setup of the microphone levels (see page 23). Connect the white and red phono plugs to the audio inputs on your monitor or speakers.

## **Recording Lamp**

The DVR3 Recording Lamp will be illuminated whenever a video recording is being made.

## **Recommended Vehicle System Power connections**

Power for the STACK synchronised video logging system must be connected to a permanent power supply such as the Master switch and not to the switched Ignition supply. This arrangement allows the engine to be switched off before the power to the STACK system.

- ! *Failure to stop DVR3 from recording before the power is removed will cause up to the last 20 seconds of the video recording in progress to be lost!*

## **Downloading Video**

Before downloading will be possible, you must first obtain a sixteen-character Pincode from your STACK dealer. This is used to Authorise DataPro for use with your .

## **Authorising DataPro for**

Select the Authorise item from DataPro's File menu to pop up the Authorisation dialog box.

## Automatic recording start control

The recording status of DVR3 is automatically controlled by the Multifunction Designer.



Shown is a test based on ESPD (Engine RPM) which causes a 'Start log' command when the Engine speed rises above the specified RPM.

- ! *The 'Start Log' command will cause DVR3 to start recording.*

## Automatic recording stop control

The system must also include a 'Stop Log' command. This is because recording **MUST** be stopped before power is removed.



Shown is a test which will stop recording when the Engine Speed has fallen to zero.

- ! *Without this, the last part of the video recording may be lost when power is removed.*

## Manual recording control

Additionally, recording can be initiated using the DVR3 Record Switch. Setting the Record Switch to On will cause video recording to start.

To stop DVR3 recording, the Record Switch must be set to Off.

## Chapter 4. Operation

### To make a recording:

Check that video, power and a Record Switch are connected as described in Chapter 3. Check that the Record Switch is set to the open (off) position.

- ! *A red marker on the Record Switch indicates when it is in the recording position.*

If not already installed, open the waterproof door and ensure the Eject Button is pushed fully home. Insert a Compact Flash card into the slot until it is flush with the opening. Once inserted, close the waterproof door.

- ! *The Compact Flash card must only be inserted with its manufacturer's label facing downwards and the lip uppermost. If there is resistance, the card is probably upside down. Inserting the card incorrectly will damage DVR3 and void the warranty.*

Apply DC power and after about a 20 second delay (while the system boots up), the Status Lamp on the front panel will light showing the status of the unit.

If the Status Lamp shows static green the system is ready to record.

If the Status Lamp is not static green, refer to the table below to find out DVR3's status.

- ! *Before making a recording, ensure there is enough space available or preferably, clear the Compact Flash card (see page 4). Card space may be checked on a PC or by making a trial recording and viewing DVR3's Status Lamp (as described below).*

To start recording close the Record Switch. Once recording, the Recording Lamp will illuminate and the Status Lamp will flash green for 3 seconds with a mark space ratio showing the capacity remaining:

- With an empty Compact Flash card the Status Lamp will flash for approximately 2.7 seconds on : 0.3 seconds off.
  - With approximately 50% capacity remaining it will flash 1.5 seconds on : 1.5 seconds off.
  - With approximately 10% remaining the Status Lamp will flash for 0.3 seconds on : 2.7 seconds off.
- To stop recording, open (switch off) the Record Switch. The Status Lamp will revert to showing static green and the Recording Lamp will be extinguished.

To stop recording, open (switch off) the Record Switch. The Status Lamp will revert to showing static green and the Recording Lamp will be extinguished.

- ! Do NOT remove the CF card whilst recording is in progress because the data will be corrupted (see page 18).

The Compact Flash card may now be removed and placed into a PC with a suitable Compact Flash card slot. The table below shows the function of DVR3's front panel Status Lamp. Green generally indicates the unit is functioning correctly and red indicates a fault or reset condition

## Chapter 7. Video and Data Systems

DVR3 has a built-in CAN interface enabling it to be connected to any STACK Display or Data Logging System, to provide synchronous data and video recording. Data from the STACK system, the internal 3-axis G-sensor and the optional GPS receiver, are recorded with the video onto the CF card for subsequent replay and analysis using the DataPro software supplied.

A track-map can be calculated from the GPS data or from inertial data (speed and lateral G) allowing navigation through the video and data with pinpoint precision. Data can also be compared between two laps from different drivers, runs, cars, etc. With the addition of side-by-side video recordings and single frame-stepping through the data, you can literally 'see' where and why time is gained or lost! Up to 256 data channels can be recorded at individual rates between one and 500 samples per second (sps or Hz).

### Controlling Synchronised Video

When using a synchronised video system, control of the DVR3 recording mode is automatic. As well as the methods to start and stop recording within DVR3, recording can also be controlled by the STACK Data Monitoring system. Ensure both the Enable CAN bus and the Control Recording options are checked on the Interfaces tab. Designer's system configuration must include an optional DVR3 module for automatic CAN bus control.

### Misc.

The Misc. tab allows you to



Misc. Screen

Set properties here for the video files created on the CF card.

#### To play a recording:

Use this to reset the numeric index used in video file names on the Compact Flash card.

#### File Name Prefix

Use this to set the file name prefix used storing video files on the Compact Flash card.

#### Maximum File Size

DVR3 stores large video recordings as separate files. Use this item to select the maximum size for each file.

Operation	Status Lamp Operation	Description
Ready	Static green	DVR3 is ready to record. Video and card OK.
Video OK, No Card	Flashing long red / short green	In stand-by or unable to record with card not present or full. Video input OK. If card present, reformat with FAT32
No Video, Card OK	Flashing long green / short red	In stand-by (or unable to record) with video not present but card OK. Check Camera connection & power or check PAL / NTSC setting OK
No Video, No Card	Fast flashing red	Unable to record. Video and card not present or full, or system fault.
PC Connected	Flashing equally green / red (0.5s red / 0.5s green)	DVR3 is under external control of the DVR Configuration Utility.
Recording Memory Remaining 100% 50% 10%	Flashing green External Recording Lamp also illuminated	Recording OK. The longer the green flash the greater the memory remaining. With a new card the Status Lamp will flash for approx. 2.7 seconds on : 0.3 off. 50% remaining, lamp flashes 1.5 sec on : 1.5 off. 10% remaining lamp flashes for 0.3 sec on : 2.7 off.
Recording, No Video	Fast flashing green / red	Recording but video is not present, audio only is being recorded.
Resetting or Busy	Static red	System reset / preparing to record or card format.



## To play a recording:

DVR3 files can be played on a PC using an MPEG-2 media player.

Insert the Compact Flash card into the appropriate slot on your PC. If a slot is not available, there are a number of USB to Compact Flash card adapters available from PC vendors.

Allow the PC a few seconds to recognise the new Compact Flash card and then run “My Computer” or “Windows Explorer” to show the new drive. Double click to display the Compact Flash card contents.



My Computer / Removable Drive



DVR3 Files

DVR3 video files are MPEG-2 compliant and filenames begin with “STACK” and have a “.MPG” extension. The files are given sequential numbers starting from zero, eg, “STACK24.MPG”. With a standard Windows configuration, they will be seen as media files (see above). To play, simply double-click the file and it will be displayed. Due to the relatively slow read speed of Compact Flash cards, better results are usually obtained by transferring the required files to the PC’s hard disk before playing. With an appropriate DVD burner and software, DVR3 files may also be burnt onto DVD or Video CD for archiving without requiring modification.

## Pincodes

The Pincodes tab allows you to authorise features of DVR3 by entering a Pincode.



Pincodes Screen

## Pincode Authorisation

Enter your supplied twenty-character Pincode exactly as it appears in your documentation, then click Write Config to authorise the configuration within DVR3.

Once the Pincode has been successfully authorised the new features will no longer be greyed out on the appropriate configuration screens.

## CAN Bus Recording Control and Video Synchronisation

- ! *Data Recording is a Pincode enabled feature. Please see Pincodes below.*  
To receive data from a connected STACK Display or Data Logging System you must first enable the CAN bus. Video synchronisation requires the Enable PTS output to be checked.  
Recording control via the STACK system requires Control Recording to be checked (see Chapter 7. Video and Data Systems). If not checked, you must start recording using the DVR3 Record Switch or using an Alarm (see page 37).  
Select the correct message protocol for your system and the 1Mb/s communication rate. The ST800 protocol supports most STACK Motorsport systems and the ST900 protocol supports most STACK Engineering systems.

! *If in doubt, please consult your STACK Dealer.*

## Operation with a new Compact Flash Card

DVR3 will only operate with Compact Flash cards formatted with a FAT32 File System. Before using a new Compact Flash card check its File System by inserting into a PC and displaying the card properties by right clicking the disk icon in “My Computer”.

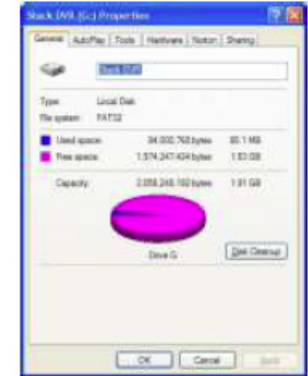

If the Compact Flash card was supplied as FAT16, reformat to FAT32 using Explorer’s format utility to select the File System (see Formatting a Compact Flash Card below).

## Formatting a Compact Flash Card

If using a new Compact Flash card, please ensure it has a FAT32 File System (see Operation with a new Compact Flash Card above). To format the Compact Flash card using Windows XP or Vista, right-click on the disk icon in “My Computer” and select “Format”. Ensure the “File system” is set to “FAT32”, choose the “Quick Format” option and then click “Start”



## Deleting Files

Whilst deleting files will release space on the removable Compact Flash card, its performance may degrade over time. Only a reformat will restore the maximum write/read speed of the Compact Flash card. So once a recording has been made which you intend to keep, transfer that file to your PC's hard drive and then perform a reformat of the removable card to keep it in top condition.

! *In summary, to keep your Compact Flash card in good condition, do not delete files. Remove files for archiving and then reformat the Compact Flash card as described above.*

## Corrupted Compact Flash Cards

If the Compact Flash card is removed, or if power is disconnected from DVR3 during a recording, it is possible the card may become corrupted or the files could be incomplete. In this case run Windows' Scan Disk routine which will help recover any missing data.

To run Scan Disk, right click on the Compact Flash card icon in My Computer and select "Properties". Select the "Tools" tab and, under "Error-checking", click "Check Now".

If the Compact Flash card is removed, or if power is disconnected from DVR3 during a recording, it is possible the card may become corrupted or the files could be incomplete. In this case run Windows' Scan Disk routine which will help recover any missing data.

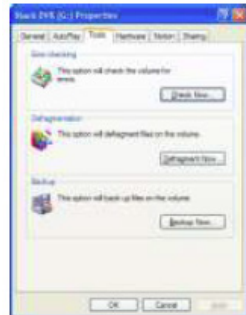

To run Scan Disk, right click on the Compact Flash card icon in My Computer and select "Properties". Select the "Tools" tab and, under "Error-checking", click "Check Now".

## Interfaces

The Interfaces tab allows configuration of the GPS and CAN Bus connections.

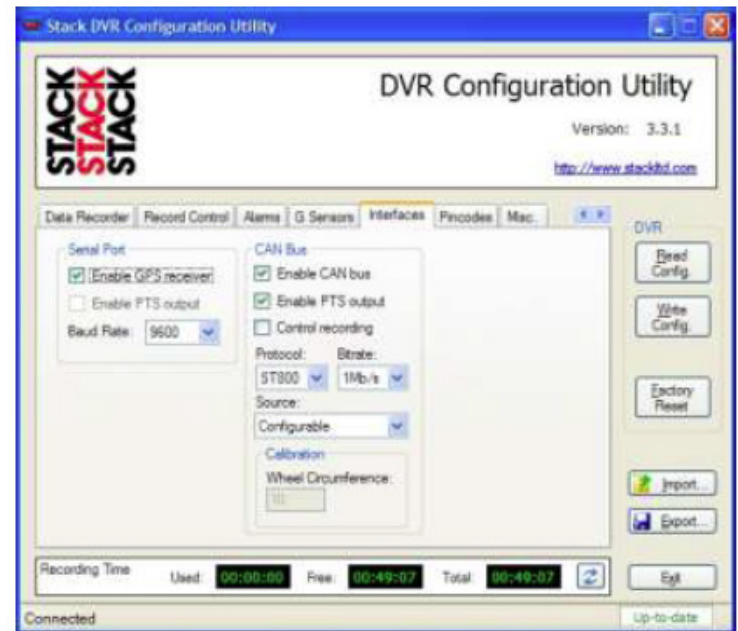

Interfaces Screen

### Serial Port

The Serial Port is used to connect a GPS Receiver which outputs NMEA 0183 serial data packets.

! *GPS overlay support is a Pincode enabled feature. Please see Pincodes below.*

After successful authorisation, check Enable GPS receiver to enable GPS channels in the Data Recorder tab. Also set the Baud rate for your GPS receiver.

! *If using a STACK ST995 GPS Receiver, set to 19200 Baud.*



## G Sensors

DVR3 is fitted with a 3-axis accelerometer which can be enabled on the G Sensors tab.



G Sensors Screen

This configuration screen allows you to enable the internal G sensors and to specify the orientation of DVR3 in relation to the vehicle it is fitted to.

It is also possible to select the sampling rate of the internal G sensors from a list.

The Check Disk dialog will now be shown. Check “Automatically fix file system errors” and click the “Start” button.

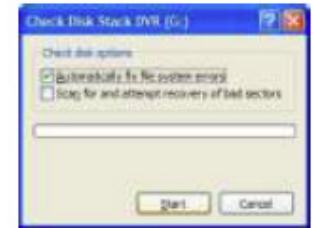

## Chapter 5. Compact Flash Cards

STACK DVR3s are compatible with most fast Compact Flash (CF) cards up to 128 Gbytes. STACK recommends Pretec and Sandisk Extreme or Ultra cards as they have been shown to give excellent results in harsh conditions.

- ! *Fitting a Compact Flash card with a greater capacity will not be recognised by DVR3 and the Status Lamp will indicate a "card not present" error (see page 15).*

Compact Flash cards will only operate if formatted as FAT32. Check any new Compact Flash card before using with DVR3. If supplied as FAT16, reformat to FAT32. For the highest quality recording it is essential that the Compact Flash card has a sustained write speed of  $\times 16$  or faster. If the card is too slow, video will play back with missing frames. This problem can be alleviated by recording at a lower video quality (see page 30).

When changing cards, always remember to follow this procedure:

- Switch off DVR3
  - Shut down the DVR Configuration Utility on your PC.
  - Disconnect the USB cable.
- Once the card has been changed you may switch DVR3 back on and reconnect the USB cable.

- ! *Do not change the card loaded into DVR3 while it is powered-up or connected to your PC. Doing so could corrupt the data and, if so, the card will need to be reformatted (see page 17).*

When used in Normal recording mode, the Post-trigger time can be used to add a delay after the stop recording trigger occurs.

### Alarms

This tab allows configuration of Alarm functions.

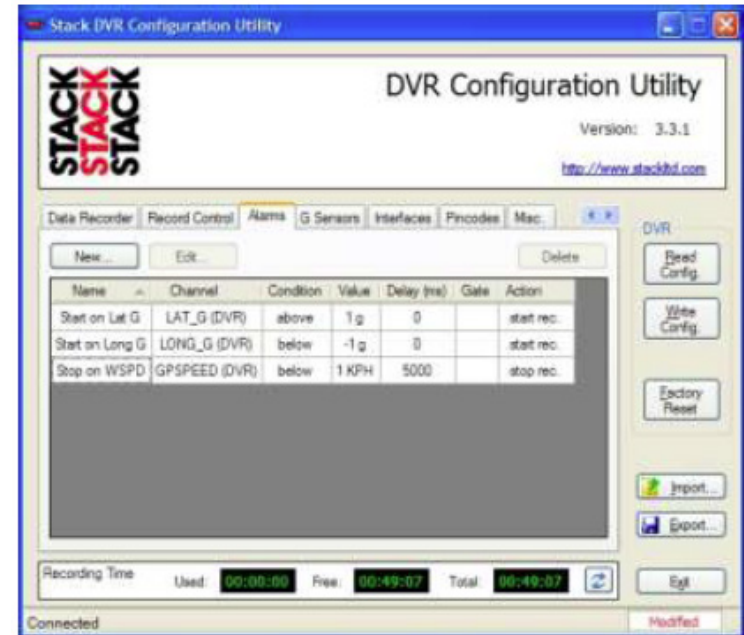

Alarms Screen

Alarms are a method of controlling features of DVR3 based on the values of data channels reaching or passing through preset limits. For example it is possible to start a video recording when the Lateral G channel exceeds 1 G.

## Record Control

This tab allows configuration of both Normal and Event recording functions.



Record Control Screen

## Recording Mode

Select between Normal and Event recording. Event recording allows recording to be triggered by an external event such as a switch changing state or a signal from a connected STACK Data Monitoring System.

## Triggering

Set the approximate length of recording before and after an event using the pre-trigger and post-trigger period controls. The Allow re-trigger checkbox selects whether an event can re-trigger recording during the post-trigger period.

## Chapter 6. Configuration

DVR3 may be configured from a PC when connected via a USB lead.

- ! Once you have finished configuring DVR3, exit the DVR Configuration Utility to update DVR3 and return it to normal operation. Alternatively, you can upload the new configuration by clicking the "Write Config" button.

### Connection

Install the DVR Configuration Utility which can be found on the CD-ROM supplied with a DVR3 system.

Once installed, connect the USB cable to a USB port on the PC. Then Run the DVR Configuration Utility on the PC.



Connection Screen

The DVR Configuration Utility will now recognise DVR3 and show that it has established a connection. Once connected the DVR3 Status Lamp will flash 50:50 red/green to indicate that it is under control of the DVR Configuration Utility (see page 15).

- ! *The DVR Configuration Utility is only able to establish connection with DVR3 when it is powered-up and has a valid CF Card installed.*

## Read Config

The DVR Configuration Utility will attempt to read the Configuration to the PC whenever it is connected to a DVR3. Clicking this button causes the current configuration to be refreshed by reading it from DVR3.

## Write Config

Clicking this button causes the new configuration to be transferred from PC to DVR3.

## Factory Reset

Clicking this button causes DVR3 to reset back to its manufacturing default settings. It should only be necessary to do this in the unlikely event that DVR3's internal set-up has become corrupted.

Once you have clicked the Factory Reset button, a dialog box will pop up and you must confirm the reset operation by clicking the "Yes" button.

Finally write this default configuration to DVR3 using the method outlined above (see page 22).

## Exit

Clicking this button closes the DVR Configuration Utility. If the configuration has been modified, you will be prompted to write the new configuration to DVR3.

channel names which contain that short string can be selected one-at-a-time by repeatedly clicking Find.

## Updating the CAN Channels List

- ! *CAN data recording is only available if the CAN bus is enabled on the Interfaces tab (see page 38).*
- If using DVR3 with a STACK Data Monitoring System (see Chapter 7. Video and Data Systems), the list of channels will be shown on this screen. Whenever you make changes to that system using DataPro Designer, no matter how small, the DVR Configuration Utility must be updated to match. You can perform that action by following this procedure :-
  1. Ensure DVR3 and the STACK Data Monitoring system are connected together by CAN and powered up.
  2. Upload the new or modified configuration from Designer.
  3. Connect DVR3 to your PC using the USB lead supplied. If the DVR Configuration Utility is not running start it now. If it is already running, just click on the Read Config. button. Both of these actions will copy the channel list from DVR3 into the DVR Configuration Utility.
- ! *If you made changes to the channels used by the STACK Data Monitoring System, those changes will be shown in the Data Recording pane.*
- 4. Now you can make changes to the DVR3 configuration (set recording rates, modify the Overlay screen etc).
  5. Finally click Write Config. to upload the configuration to DVR3.
- ! *This last action must be performed regardless of whether you made any specific changes to DVR3's configuration or not.*

## Data Recorder

This tab allows configuration of data to be recorded from the directly connected sensors (G, GPS etc) and those obtained from the CAN bus.

- ! *Data Recording is a Pincode enabled feature. Please refer to the Pincodes tab (see page 41).*

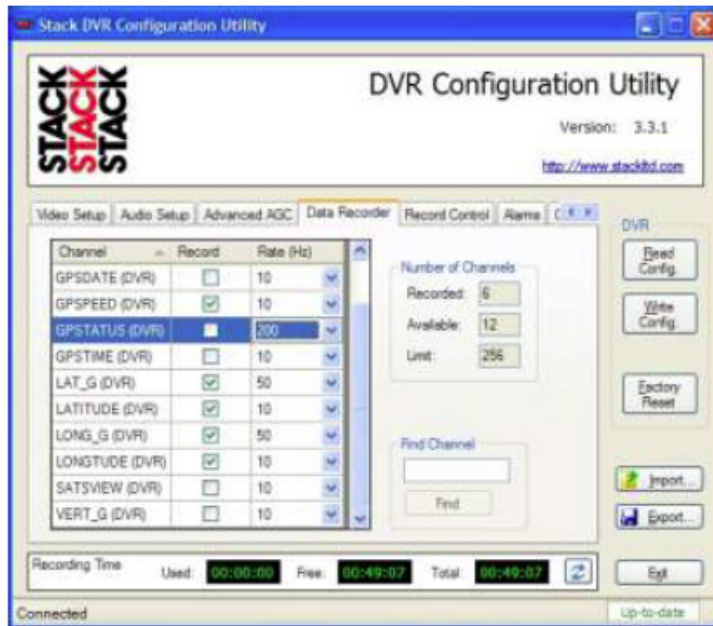

Data Recorder screen

Select the Record check boxes to enable recording for those channels. Then set their recording rates in samples per second (Hz).

Two indicators show how many channels are available to be recorded and the number of those which have been selected. If the list of channels is long, it is also possible to search that list for the desired channels. Enter one or more characters into the Find Channel box and click the Find button. All

## Information

This screen shows the serial numbers of DVR3 and the DVR Configuration Utility software.



Information Screen

If a Compact Flash card is fitted, this screen will show details of the card including an indication of the amount of space which has been used.

Click the “Format” button to display the Windows Format dialog box which can be used to format the Compact Flash card (pre-2010 models only).

Click the “Upgrade” button to upgrade the firmware in DVR3 (see Appendix C. Upgrading the Firmware).



## Video Setup

This screen allows you to configure the various aspects of the video recorder.

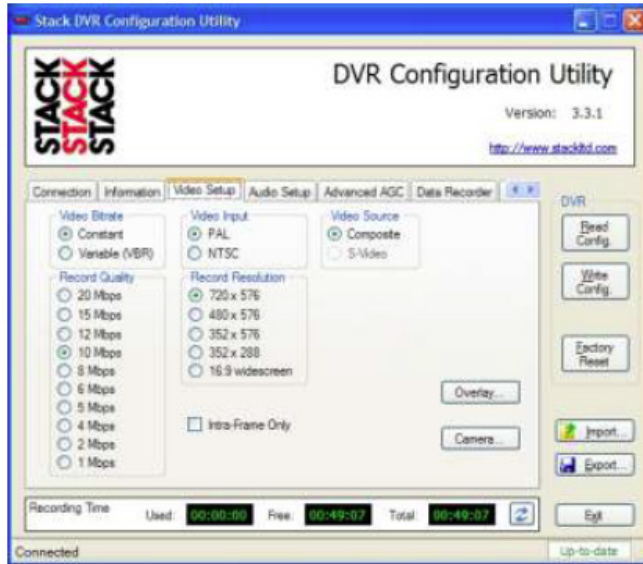

Video Setup Screen

## Record Quality

Allows you to configure the amount of compression employed by the system. The software shows an estimate of the record time at the bottom of the screen, depending upon configuration.

## Record Resolution

Allows you to adjust the resolution of the recordings to those shown in the table below. The software shows an estimate of the record time at the bottom of the screen, depending upon resolution.

Example	1	2	3
Target Level	-5.5 dB	-5.5 dB	-10 dB
Attack Time	8 ms	20 ms	20 ms
Decay Time	500 ms	500 ms	500 ms
Noise Threshold	-90 dB	-90 dB	-90 dB
Maximum Gain	59.5 dB	50 dB	40 dB
Hysteresis	2 dB	Disabled	2 dB
Noise Debounce	0 ms	0 ms	2 ms
Signal Debounce	0 ms	0 ms	0 ms

### Example 1

Without speech or signal, decrease the Maximum Gain to have an acceptable level of amplified noise. Next, with the lowest speech or signal source, increase the Noise Threshold variable to a level so that the weak signal can be detected and gained. Then, increase the Attack Time if the speech initially sounds bad; decrease the Decay Time if the speech sounds too noisy for too long at the end.

### Example 2

With these settings the background noise may become considerable when noise is beyond the Noise Threshold because the Maximum Gain is higher (+50 dB). Thus big noise may get louder because of the higher gain.

### Example 3

With these settings, although the noise may be above the Noise Threshold, there will not be as much gain as in Example 2. The AGC output gain has also been reduced due to the smaller Maximum Gain.

**Target Level:** The desired nominal output level.

**Maximum Gain:** Limits the gain applied to achieve the Target Level.

- ! *Set by the Left/Right Volume slider controls on the Audio Setup tab (see page 30).*

**Attack Time:** Time taken by the AGC to respond to an input signal increase.

**Decay Time:** Time taken by the AGC to respond to an input signal decrease.

**Noise Threshold:** Signals lower than the threshold will be muted (silenced).

**Noise Gate Hysteresis:** Widens the on & off levels for the noise threshold.

**Detection Debounce Noise & Signal:** Time Delay to avoid rapid activation of the noise mute/silence feature.

**Clip Stepping:** Reduces the audio level automatically when the signal exceeds the maximum allowed (clips).

- ! *Note. Do not use Clip Stepping & AGC together.*

## AGC Application Examples.

Three examples for the AGC setup follow.

1. Used as the starting point in general.
2. Used for an application where the noise is small compared to the input signal amplitude.
3. May be more suitable as the starting point for a condition where noise is relatively large.

The following examples can be used as a guide to setting the Advanced AGC parameters :-

Resolution	PAL	NTSC
Full	(D1) 720 x 576	720 x 480
Medium	(2/3 D1) 480 x 576	480 x 480
Small	(1/2 D1) 352 x 576	352 x 480
Smallest	(SIF) 352 x 288	352 x 240
16:9 Widescreen	720 x 400	720 x 400

- ! *Always test that the recordings which are made will play correctly on your video equipment. Many domestic DVD players will not play back correctly unless the recordings were made at the Full (D1) resolution.*

## Video Input

Configures the system to either PAL or NTSC.

## Video Source

Configures the system to either Composite or S-Video

- ! *DVR3s do not support the S-Video input.*

## Video Bitrate

This option is used to enable Constant or Variable Bit Rate support.

- ! *Variable Bit Rate is only available on DVR3-540.*

## Intra-Frame Only

Check this box to enable intra-frame only compression.

- ! *I-Frame recording is only available on DVR3-540.*

## Video Overlay

To configure the video overlay select the Video Setup tab and then click the Overlay button to access the video overlay configuration screen.

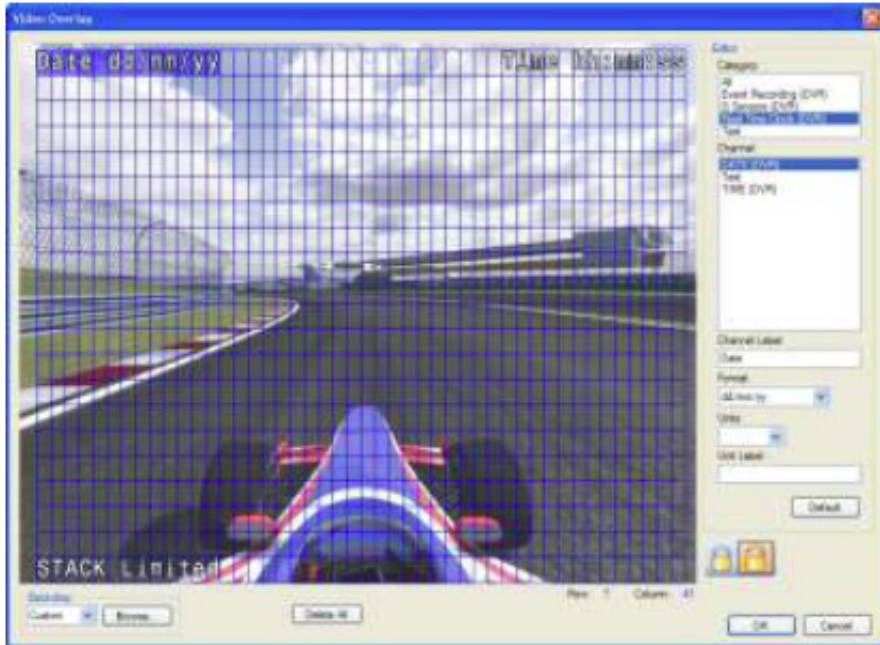

### Video Overlay Screen

To overlay text simply click on any of the blank cells within the display grid and start typing.  
 To overlay the date or time from DVR3's real-time clock, click on any of the cells within the display grid and select the All or Real Time Clock option from the Category list. Then select the Date or Time option from the Channel list. You may customise the selected overlay channel by entering your own text in the Channel Label and/or Unit Label boxes. You may also select a different Format or Units option using the dropdown boxes where available.  
 To reposition an overlay channel simply left-click and drag the channel on the display grid to a new location.  
 To delete an overlay channel click on the desired channel in the display grid and press the Delete key on your keyboard.  
 To delete all the overlay channels click the Delete All button.

- ! Only one instance of each channel, except the Text channel, is allowed on the overlay.

## Advanced AGC

As well as a highly advanced video processor, DVR3 also incorporates a sophisticated sound processor used for Active Gain Control. For most applications the standard gain control on the Audio Setup tab will be all you require. However, if that doesn't perform adequately for your application, the controls on this tab will allow a knowledgeable person to adjust the sound quality, for example, to enhance speech or to reduce unwanted background noise. The examples below give good starting points but, achieving the ultimate performance will require experimentation.

- ! In order to use this screen, Audio must be enabled and AGC checked on the Audio Setup tab (see page 30).



### Advanced AGC screen



## Audio Setup

This screen allows you to configure the various aspects of the audio recorder.

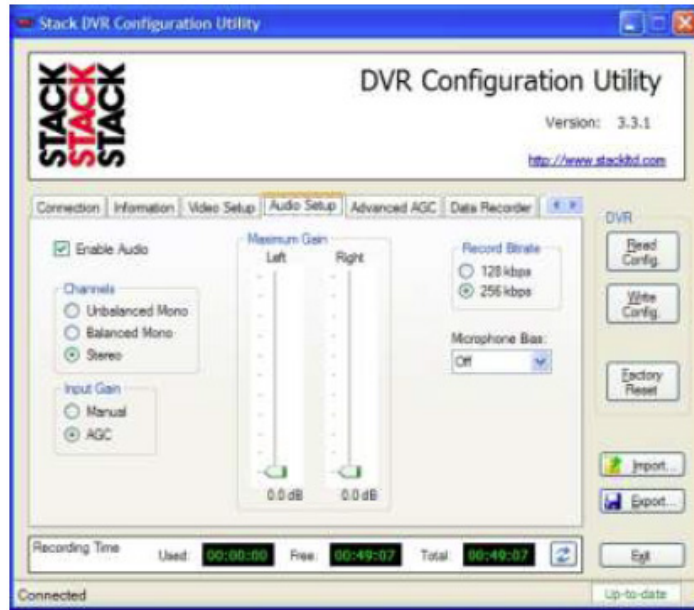

Audio Setup Screen

Set Input Gain to use Automatic Gain Control for audio inputs. This will enable the Advanced AGC tab options. You can use Record Btrate to set the amount of compression applied to the audio signal. Set Microphone Bias to On if your microphone requires a bias voltage supply.

- ! Uncheck Enable Audio if you do not want to record audio;
- that will free more space for video recording.

## Camera Configuration

To configure the cameras select the Video Setup tab and then click the Camera button to access the camera configuration screen.



Camera Configuration Screen

To enable a camera check the box on the right of the configuration screen, eg, Camera 1, Camera 2, etc. If the Capture Mode is set to Auto, the software will immediately start to capture the image on the enabled camera(s). Once the camera images have been captured you may then modify the configuration. Use the selection rectangles on the right of the screen to crop the camera image. Click and drag any node on the rectangle to resize the crop area. Click and drag within the rectangle to select a different part of the camera image. Controls for Border, Mirror and Flip are also located on the right of the configuration screen. Use the "Colour Settings"

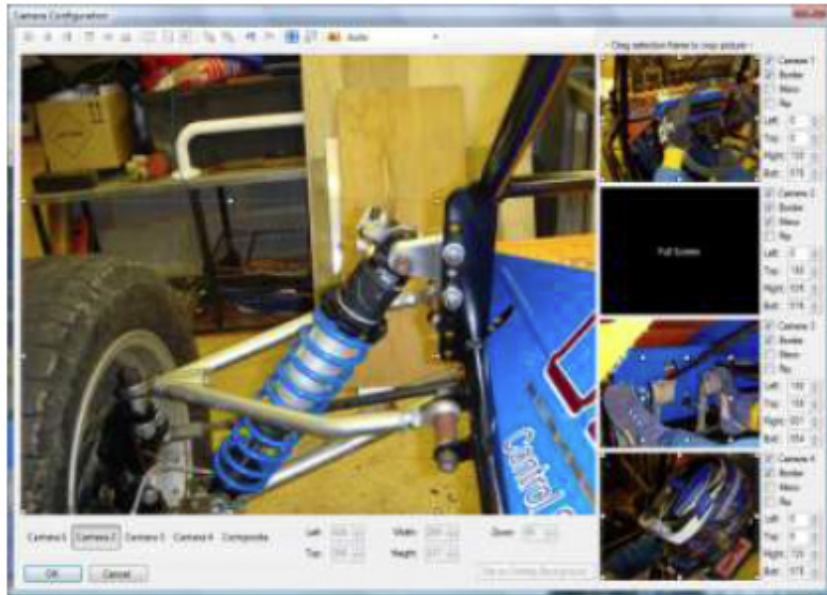

**Full Screen Crop Window**

You may enlarge the input camera window for more precise positioning by clicking the appropriate Camera 1, Camera 2, etc buttons on the bottom left of the screen. The right side of the configuration screen shows an enlarged video picture. Select "Composite" to display the recorded output image. You can now click and drag any of the individual windows in the composite screen, to reposition them. Drag a window by its corner to maintain the aspect ratio of the image when resizing. The system will not magnify camera images so the maximum zoom is 1:1, ie, 100%. Use the toolbar buttons Send to Back and Bring to Front to arrange how the windows overlap each other. For a quadrant style layout of four equal windows, click the quadrant button on the toolbar as below.

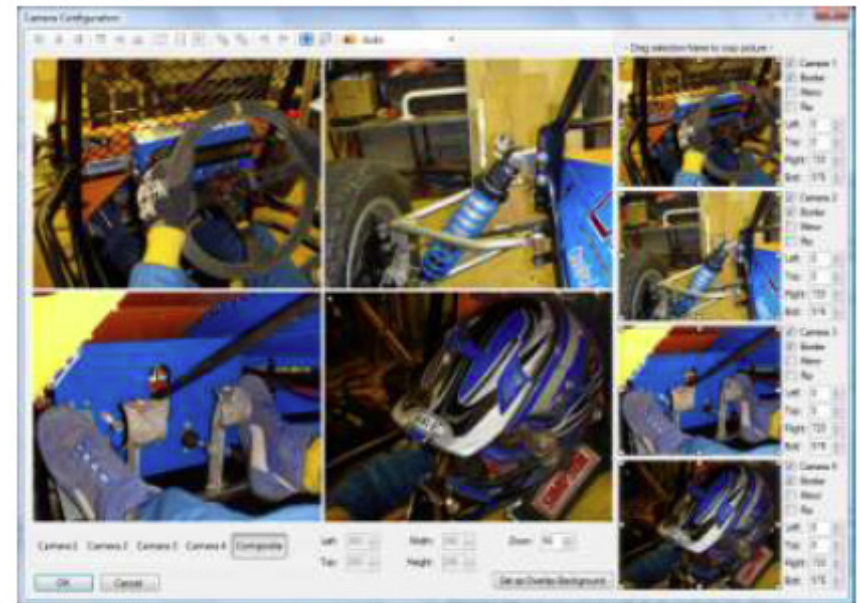

**Quadrant Style Output**

To maximise a window, first select the window by clicking it, then click the maximise button on the toolbar. Selecting more than one window by holding down the Ctrl key while clicking the windows will enable the alignment buttons on the toolbar. If you are using Text Overlay, you may click the Set as Overlay Background button to use the current composite image as a background for the Overlay configuration screen. Click the OK button when configuration is complete. Then click Write Config. to save the changes to DVR3.